

ISO

1)BOTTOM.
2)TOP.

Dept. MECH	Technical reference	Created by HEMANTH C	9/3/2020	Approved by PRATHEEK	9/3/2020
		Document type PDF	Document status		
		Title PES01(SMALL) PROBOTS	DWG No. 1		
		Rev.	Date of issue 9/3/2020	Sheet 1/2	

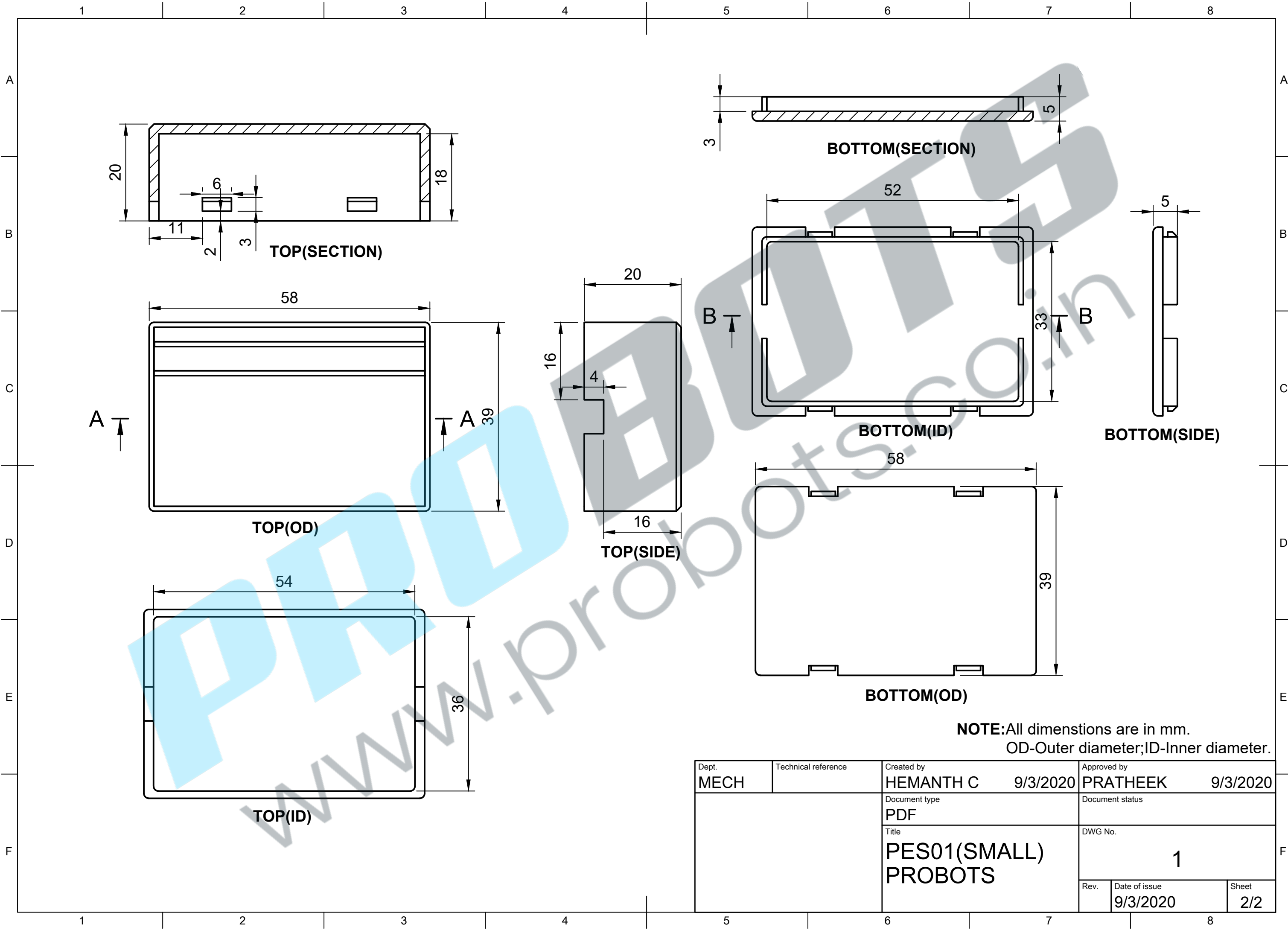

NOTE:All dimenstions are in mm.
OD-Outer diameter;ID-Inner diameter.

Dept. MECH	Technical reference	Created by HEMANTH C	9/3/2020	Approved by PRATHEEK	9/3/2020
		Document type PDF	Document status		
		Title PES01(SMALL) PROBOTS	DWG No. 1		
		Rev.	Date of issue 9/3/2020	Sheet 2/2	